

nola®

Nola > Products > Luma



The Luma park bench can be custom-made in a range of materials to almost any desired length.

Luma Park Bench

DESIGN ERIK ÖSTERLUND

The Luma park bench easily blends into a variety of outdoor settings. The design is very subtle, combining an efficient steel frame with the understated beauty of oak. The Luma park bench can be custom-made in a range of materials to almost any desired length. The bench can be ordered as a straight length or form part of a curve that creates a crescent shape. Luma can be wall-mounted and ordered with or without armrests.

CERTIFICATION

 **SundaHus**

 **BYGGVARU
BEDÖMNINGEN**

Produkt listad i
Svanens Husportal

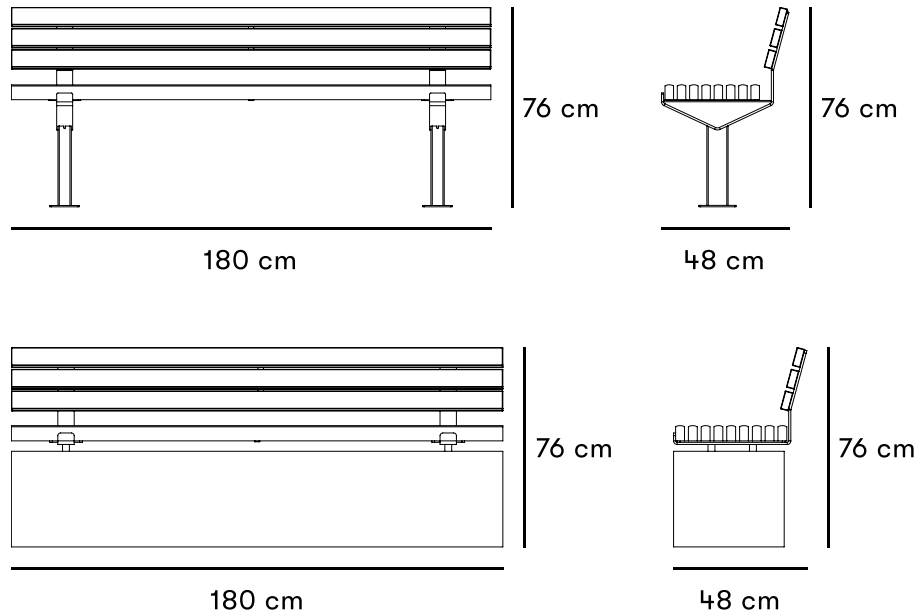

Dimensions and weight

Length: 180 cm / 260 cm

Width: 48 cm

Height: 76 cm

Sitting height: 46 cm

Enskilda dimensioner

The steel supports underneath: 80 x 50 x 2 mm

The flat steel parts forming the seat and backrest: 60 x 8 mm

Wood components: 32 x 56 mm

Optional tabletop: Thickness: 6 mm

Product numbers and combinations

U18-48/180

Luma park bench
180 cm

U18-48/260

Luma park bench
260 cm

U18-49R

Luma armrest

U18-35/BORD

Attachable
tabletop

B11-05

Additional fee for
non-standard
wood

B11-06

Additional fee for
choosing a non-

standard colour on
steel

Append to product number

WOOD AND FINISH

EK for oiled oak.

METAL SURFACE FINISH

C for choice of non-standard colour,
additional fee is added.

VARIANTS

Luma can be produced in single, non-
standard lengths up to a maximum of
260 cm. If longer lengths are required
they will have to be divided into
sections.

INSTALLATION TYPE

N for surface mount.

M for in-ground.

V for mounted to wall.

MUR for mounted on wall.

Standard colours

RAL 7011

Materials and surface treatments

Steel

Nola uses high-quality steel with good
strength in our products. Steel rusts if
left untreated and must therefore be
surface treated. This is done through
electro-galvanization and powder
coating, hot-dip galvanizing, or
application of a zinc powder primer.

Oak

Oak is a heavy, hard and medium tough
wood. Moderately dimensionally stable
in case of moisture changes. Oak wood
blackens if it is exposed to moisture or
wetness for a long time. However, it does
not affect the other properties of the

wood. Thanks to its hardness and toughness, the oak wood is suitable for furniture and other use in exposed environments.

Wood oil

Wood oil provides good protection against the stresses of the outdoor climate and at the same time highlights the wood's natural appearance and properties.

Electrogalvanized

Electrogalvanizing (also known as zinc plating) provides corrosion protection through the sacrifice of zinc ions. It is created via a zinc coating on the steel using an electric current.

Powder coating

Powder coating is a coating that is applied as a free-flowing, dry powder. Unlike conventional liquid paint, powder coating is usually applied electrostatically and then cured under heat or with ultraviolet light. The result is an even, hard-wearing coloured surface with the desired gloss level.

Assembly and placement

In-ground

Cast in ground.

Surface mount

Can be bolted above ground, to the floor or to a cast-in-place foundation. Bolts not included.

Mounted on wall

Frames are attached to concrete or stone walls with expanders or chemical anchors. Seat sections mounted on top of walls are attached to the frames.

Fasteners for mounting on top of walls not included.

Mounted to wall

Bolted in place to stand/wall bracket.

Bolts for walls not included.

The seat is delivered fully assembled for installation to the frame on-site with the bolts included. The bolts for attaching the frame to the ground or wall are not included.

Maintenance

Oiled oak

Oiled oak should be oiled twice a year for best protection. Good maintenance can never completely prevent stains from occurring, but oak that is not maintained will turn blacker and turn gray faster, but it still has a very long life. When re-oiling products, a finely boiled oil that penetrates the wood should be chosen over a film-forming oil.

Powdercoated steel

Products that are electro-galvanized and powder-coated can be touch-up painted with alkyd paint.

Download our general maintenance advice

Versions

Luma is available in standard lengths of 180 cm and 260cm. An attachable

tabletop is available. Freestanding, attachable, ground-mounted, wall-mounted and wall-top versions are available.





Sign up for our newsletter

Send



Contact

Head Office Stockholm

Nola Industrier AB
Box 17701
Repslagargatan 15b
118 93 Stockholm
Tel: 08-702 1960
Fax: 08-702 1962
headoffice@nola.se

Sales Office / Showroom Malmö

Nola Industrier AB
Neptunigatan 74
211 18 Malmö
Tel: 040 171 190

